

Product number: IN-2363

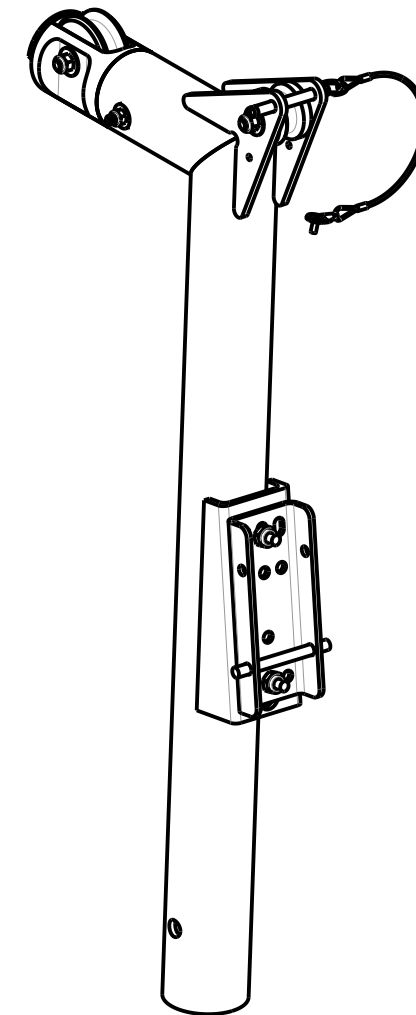

PAT.NO.:

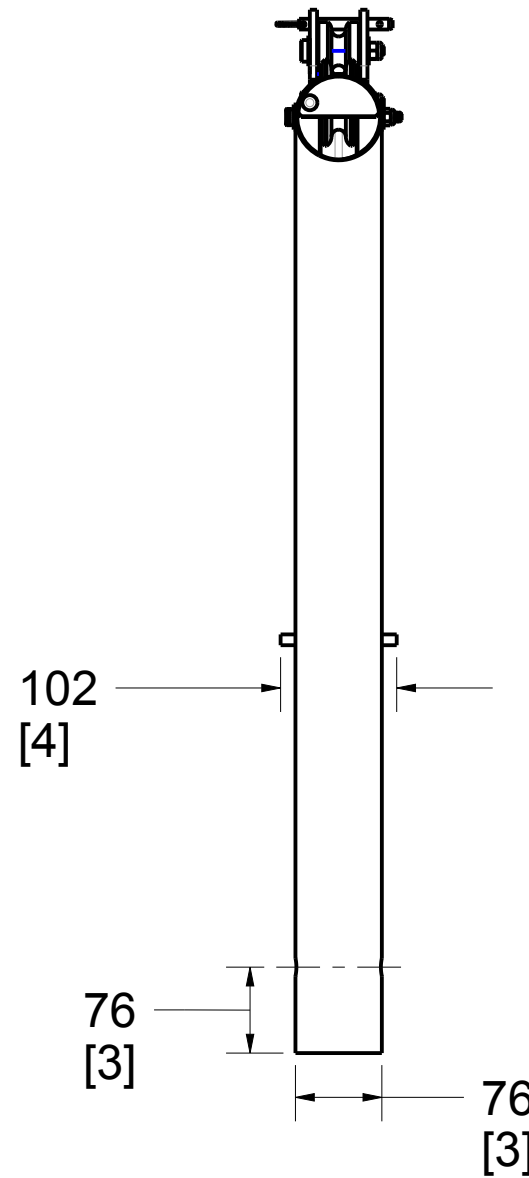
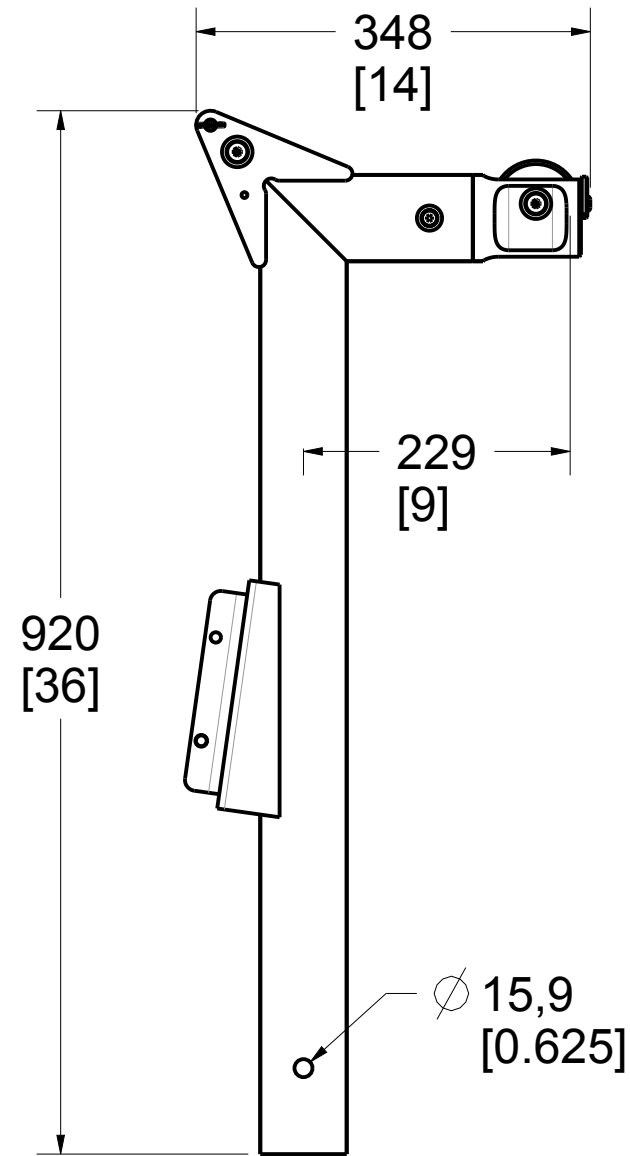

PRODUITS DE SERVICE PUBLICS INNOVA INC.  
INNOVA PUBLIC UTILITY PRODUCTS INC.

© 9105-0732 QUEBEC INC. and under exclusive license to INNOVA PUBLIC UTILITY PRODUCTS INC., (hereafter « INNOVA »). All rights reserved. Protected under the Copyright Act of Canada and international treaties and agreements regarding copyrights. Violators are subject to prosecution and other legal recourses for infringement. Any reproduction, adaptation or other use or disclosure whatsoever, in totality or in part, and in any form or by any means whatsoever, strictly forbidden and requires the prior written approval of INNOVA. All data is the exclusive property of 9105-0732 QUEBEC INC. and under exclusive license to INNOVA and cannot be used nor disclosed in any way either without the prior written approval of INNOVA.

WEIGHT:

TITLE:

15.0 Lb

76mm (3") Mast / Davit-Arm

6.8 Kg

914mm (36") x 229mm (9") Reach

COLOR:

Yellow  
XTIRPA

Material:

Aluminum

SHEET(S):

1 / 4

PROJET:

IN-2363

Rev.

03

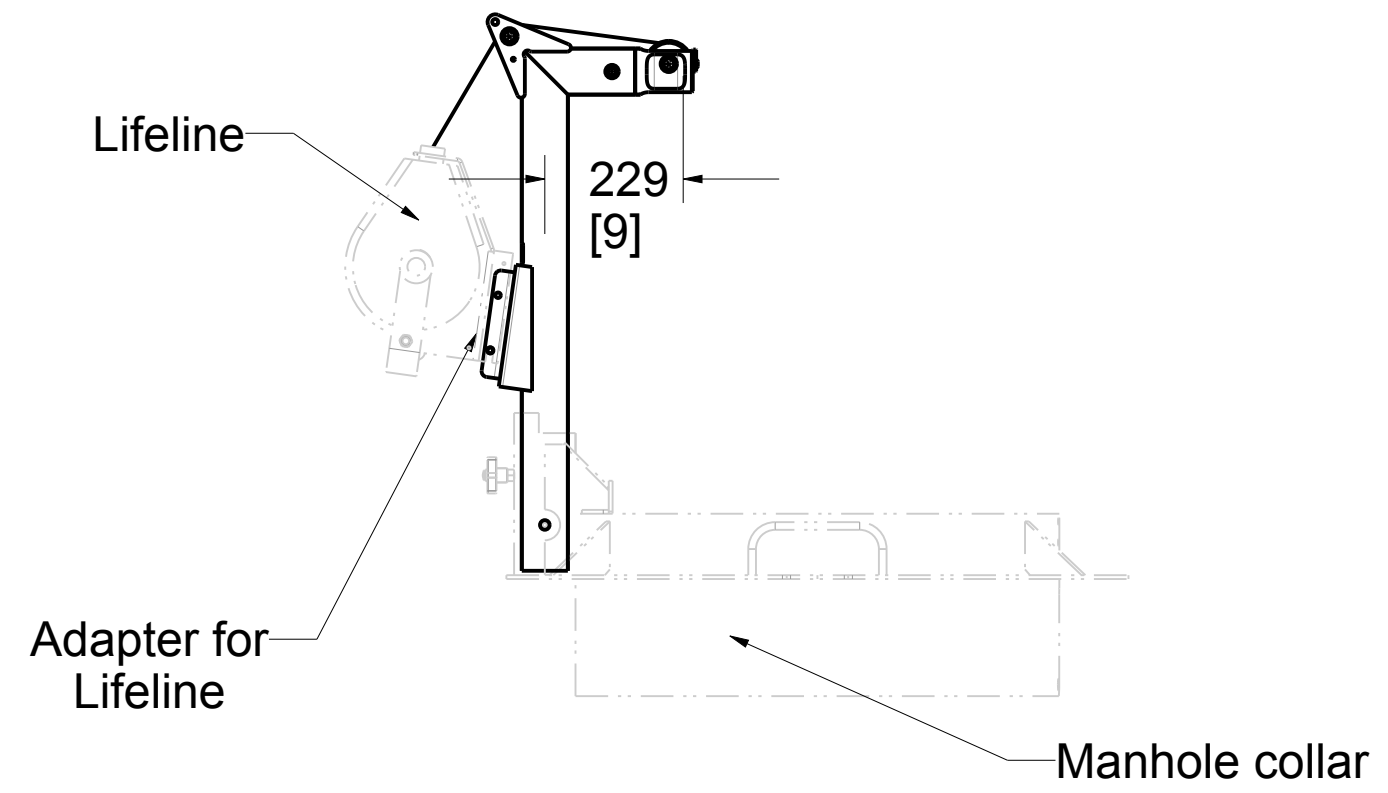
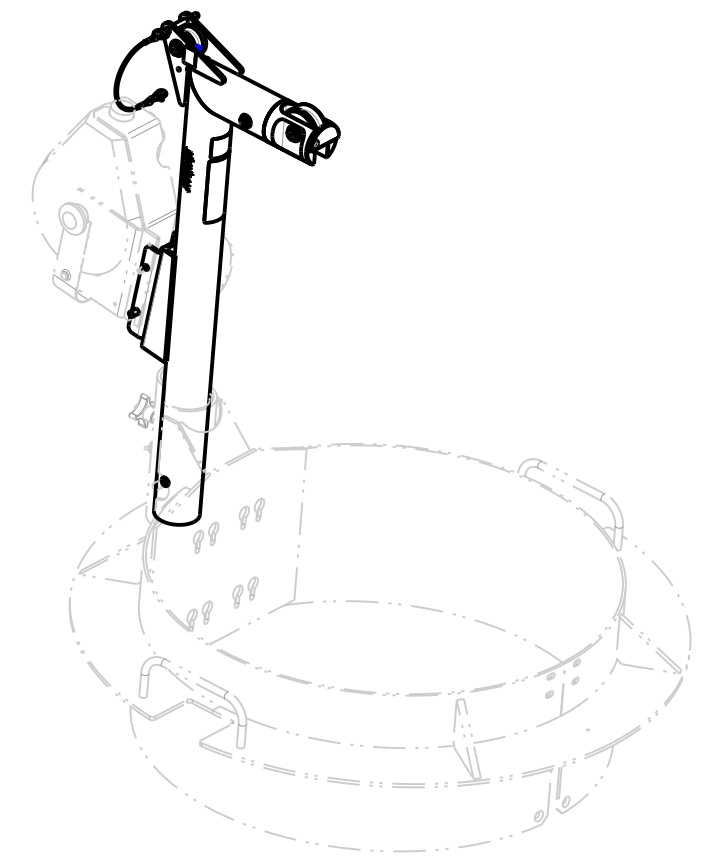
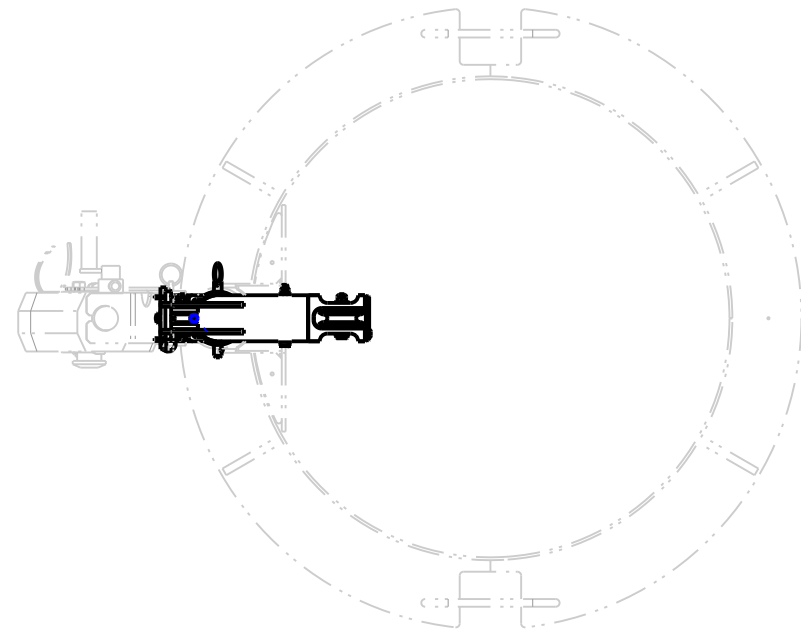

PAT.NO.:				
<b>PRODUITS DE SERVICE PUBLICS INNOVA INC.</b> <b>INNOVA PUBLIC UTILITY PRODUCTS INC.</b>				
© 9105-0732 QUEBEC INC. and under exclusive license to INNOVA PUBLIC UTILITY PRODUCTS INC., (hereafter « INNOVA »). All rights reserved. Protected under the Copyright Act of Canada and international treaties and agreements regarding copyrights. Violators are subject to prosecution and other legal recourses for infringement. Any reproduction, adaptation or other use or disclosure whatsoever, in totality or in part, and in any form or by any means whatsoever, strictly forbidden and requires the prior written approval of INNOVA. All data is the exclusive property of 9105-0732 QUEBEC INC. and under exclusive license to INNOVA and cannot be used nor disclosed in any way either without the prior written approval of INNOVA.				
WEIGHT:	TITLE:			
15.0 Lb	76mm (3") Mast / Davit-Arm			
6.8 Kg	914mm (36") x 229mm (9") Reach			
COLOR:	Material:	SHEET(S):	PROJET:	Rev.
Yellow XTIRPA	Aluminum	2 / 4	IN-2363	03

**SPECIFICATIONS**

H This equipment is considered as part of a personal fall arrest system (PFAS).

It is only to be used in conjunction with a personal fall arrest system that limits the maximum arrest force (MAF) to 6.0 kN.

G Working load limit (WLL) : 164 kg (360 lb)  
 Minimum breaking strength for anchorage 1 (F1) : 16,0 kN (3 600 lbf)

**STANDARDS**

Name	Classification	Year	Users
ANSI Z359.1		2007	1
CSA Z259.2.1		1998 (R2011)	1
OSHA 1910.66			1
EN 795	A,B,E		1
TS 16415		2013	1

**MATERIAL AND CONSTRUCTION**

D Structure : Aluminum  
 Welding procedure : CSA W59,2 / CSA W47.2 & CSA W59.18 / CSA W47.1  
 Surface Finishing : Yellow XTIRPA

**RESTRICTIONS**

B This equipment is to be used only with products approved by Innova Public Utility Products Inc.

This equipment must always be operated on a level surface.

Ensure that all hardware and connecting pins are properly installed before use.

A In the occurrence of a fall or the safety of the equipment is in doubt, the equipment must be immediately removed from service and inspected by qualified personnel before reuse.

Product number: **IN-2363**

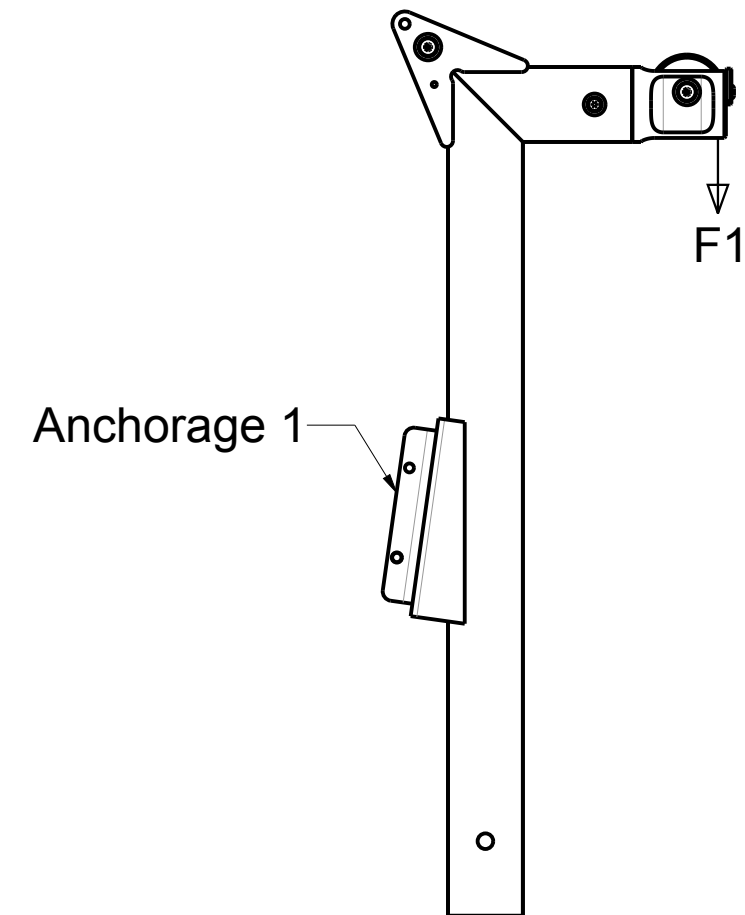

**Also Available Clear Anodized**

PAT.NO.:				
PRODUITS DE SERVICE PUBLICS INNOVA INC. INNOVA PUBLIC UTILITY PRODUCTS INC.				
<small>© 9105-0732 QUEBEC INC. and under exclusive license to INNOVA PUBLIC UTILITY PRODUCTS INC., (hereafter « INNOVA »). All rights reserved. Protected under the Copyright Act of Canada and international treaties and agreements regarding copyrights. Violators are subject to prosecution and other legal recourses for infringement. Any reproduction, adaptation or other use or disclosure whatsoever, in totality or in part, and in any form or by any means whatsoever, strictly forbidden and requires the prior written approval of INNOVA. All data is the exclusive property of 9105-0732 QUEBEC INC. and under exclusive license to INNOVA and cannot be used nor disclosed in any way either without the prior written approval of INNOVA».</small>				
WEIGHT:	TITLE:			
15.0 Lb	76mm (3") Mast / Davit-Arm			
6.8 Kg	914mm (36") x 229mm (9") Reach			
COLOR:	Material:	SHEET(S):	PROJET:	Rev.
Yellow XTIRPA	Aluminum	3 / 4	IN-2363	03

Product number: IN-2363

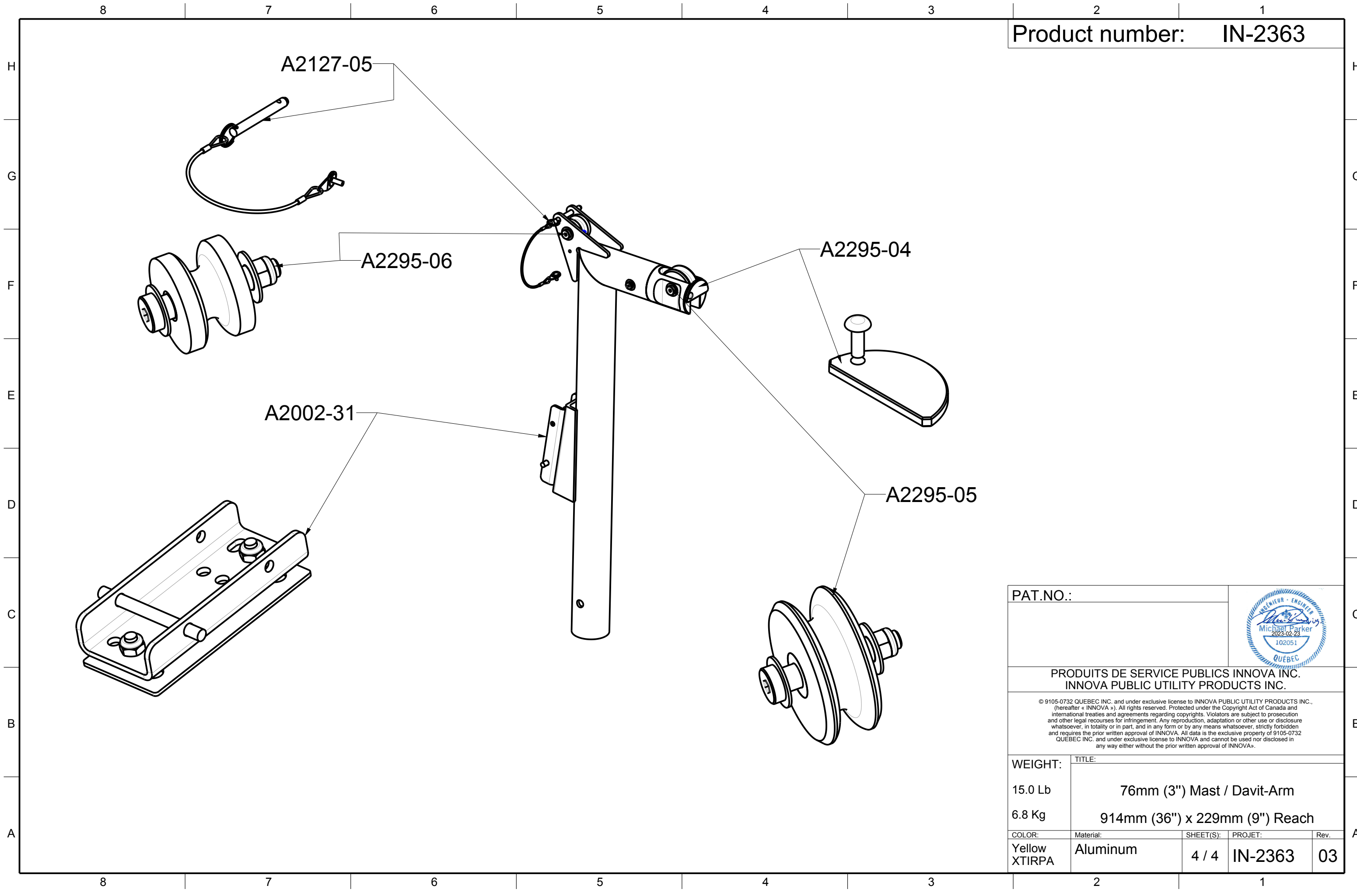

PAT.NO.:				
<b>PRODUITS DE SERVICE PUBLICS INNOVA INC.</b> <b>INNOVA PUBLIC UTILITY PRODUCTS INC.</b>				
© 9105-0732 QUEBEC INC. and under exclusive license to INNOVA PUBLIC UTILITY PRODUCTS INC., (hereafter « INNOVA »). All rights reserved. Protected under the Copyright Act of Canada and international treaties and agreements regarding copyrights. Violators are subject to prosecution and other legal recourses for infringement. Any reproduction, adaptation or other use or disclosure whatsoever, in totality or in part, and in any form or by any means whatsoever, strictly forbidden and requires the prior written approval of INNOVA. All data is the exclusive property of 9105-0732 QUEBEC INC. and under exclusive license to INNOVA and cannot be used nor disclosed in any way either without the prior written approval of INNOVA®.				
WEIGHT:	TITLE:			
15.0 Lb	76mm (3") Mast / Davit-Arm			
6.8 Kg	914mm (36") x 229mm (9") Reach			
COLOR:	Material:	SHEET(S):	PROJET:	Rev.
Yellow XTIRPA	Aluminum	4 / 4	IN-2363	03